

SP-50HAM



Scale & Sliding Cylinder with Handle



Winch Handle Holder



Winch Protection Cover



V-Block & 180° Guiding Design



Special Design for More Height Position of Working Bench



Dustproof Cover



Screw Extension



Punches Set



Pulley Protection Cover



Handle Assy Holder

Model	Capacity	Net Weight	Packing Size	Working Air Pressure	A	B	C	D	E	G1	G2	R	R1	R2	M
SP-50HAM	50t	240kgs	185.5x100x40.5cm	0.9-1.2Mpa	930	750	1900	200	535	80	780	220	145	75	280

SP-50HAM

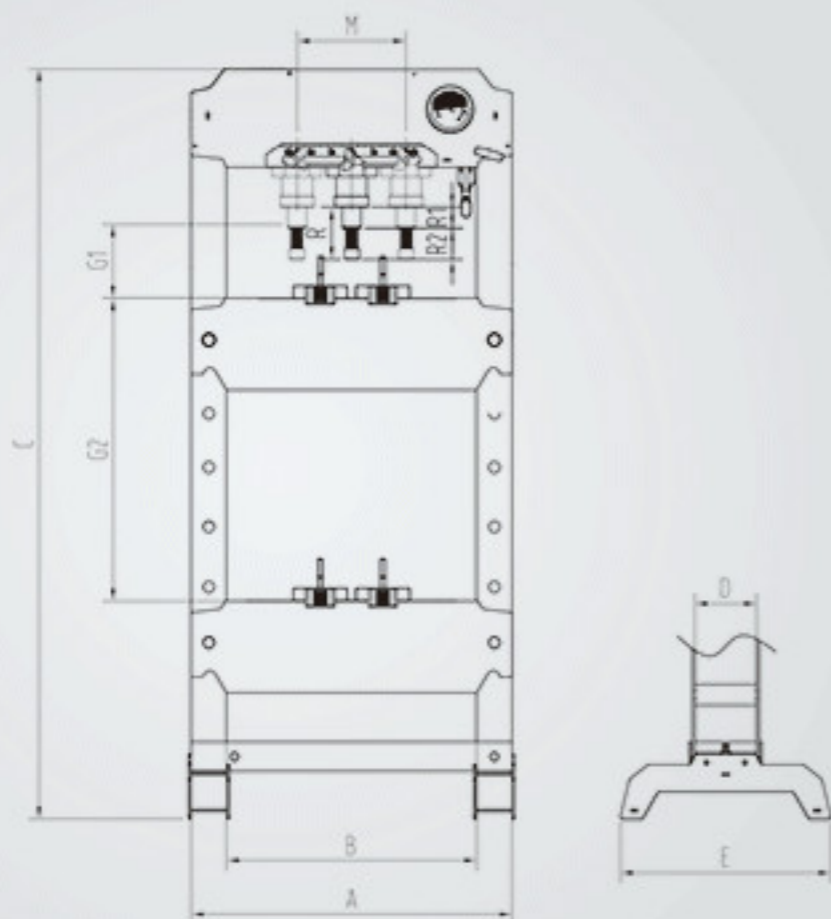

Features

- Safety valve
- Industry seals
- Protection cover
- Removable parts tray
- Foot pedal for pneumatic operation
- Robots welding and laser cutting frame
- Winch swiveling handle and winch handle holder
- Ergonomics operation handle and handle assy holder
- Pneumatic and manual pump with double speed action
- Winch protection cover and pulley protection cover for hand safety